

# T100MD-2424+ PLC Installation Guide

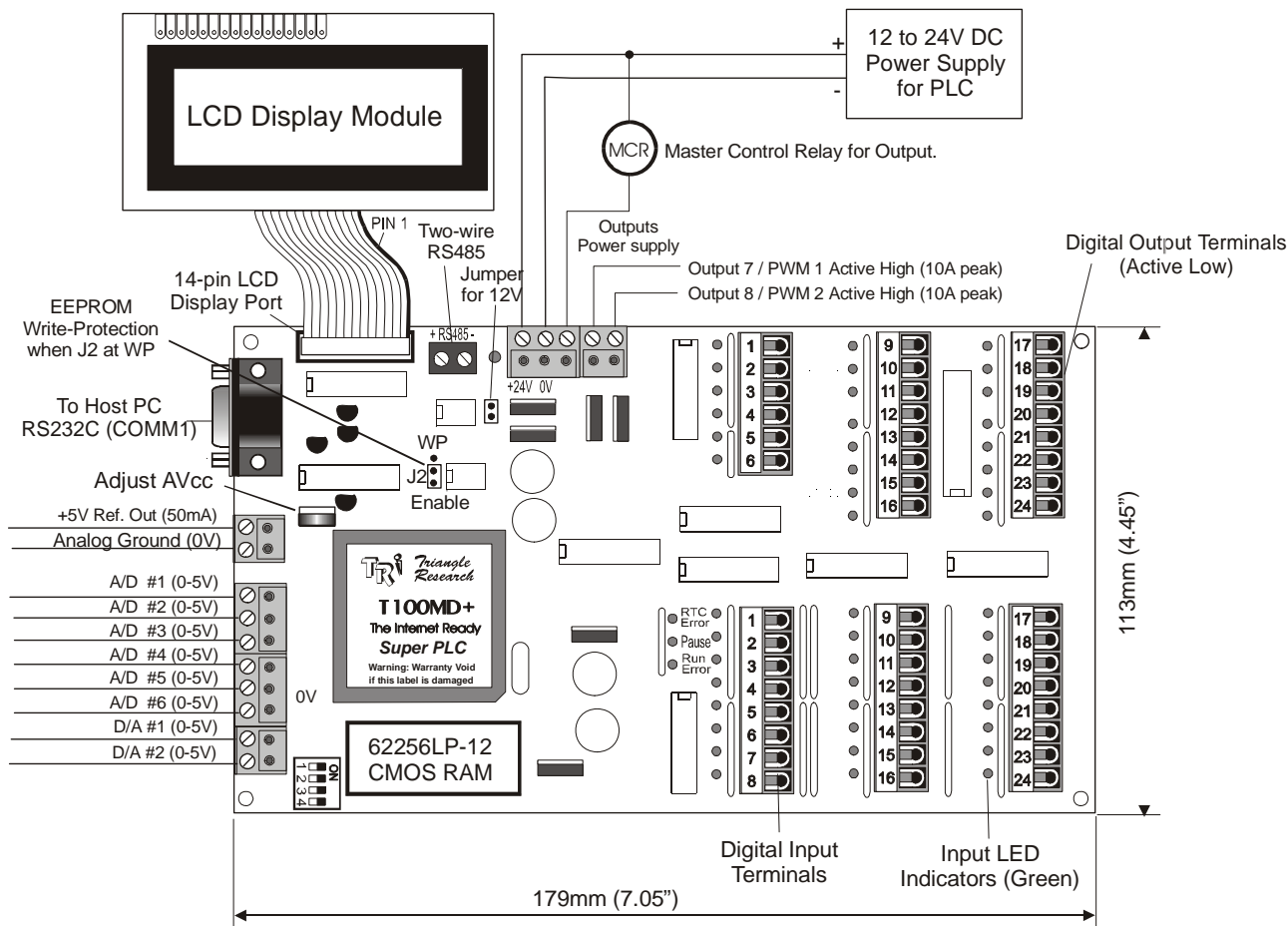

Figure 1 - T100MD-2424+ and a LCD Module

## 1. Introduction

T100MD2424+ is a new member of the highly popular T100MD+ PLC family. The basic unit comprises 8 analog I/Os, 24 digital Inputs and 24 digital outputs. Two of the digital outputs (7 & 8), which can be also defined as **PWM outputs**, can each deliver up to **10A peak** and 2A continuous, 24VDC (active high) current to the load. The 8 analog I/Os are configurable as 8 AI, no AO or 6 AI and 2 AO. All analog inputs are 10-bit resolution and all analog outputs are 8-bit resolution.

T100MD2424+ is expandable up to a total of 96 digital inputs and 96 digital outputs with an optional expansion module. It has an RS232 and an RS485 ports, both of them are conversant in MODBUS protocol. The built-in LCD port allows simple interface to industry-standard LCD modules from 8 characters to 80 characters!

## 2. Physical Mounting & Wiring

The compactly designed T100MD2424+ PLC can be easily installed in many kinds of plastic or metal enclosures. You need to use 4 or 5 PCB standoffs (or some screws and nuts) to support the controller and fasten it to a console box.

**Analog I/O Ports:** The 8 channels of analog I/Os are available via an 8-way detachable screw terminal connector along the left edge of the T100MD2424+ PLC. The PLC also supplies a +5V analog reference-voltage output and the analog ground on a separate two-way detachable screw terminals as shown in Figure 1.

The specifications and programming methods for the analog I/Os are detailed in Section 8 of this Installation Guide.

**Digital I/O Ports:** Detachable screw terminals are provided for quick connection to all digital inputs, outputs and power supply wires. Each block of screw terminals can easily be detached from the controller body, enabling easy replacement of the controller board when necessary. Since the terminal block for digital I/Os is inserted vertically to the board surface, you need to remove the terminal block before you can start wiring. Use a small flat-head screwdriver and insert underneath the terminal block, apply even pressure to raise the terminal block until it becomes loosened from the connecting-pin strip, as shown below:

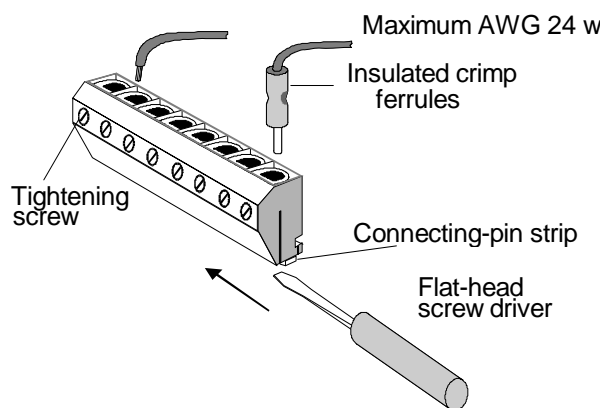

Figure 2 - Removing Screw Terminal block

Although wires of up to 24 AWG may be connected directly to the screw terminal, insulated crimp ferrules should be used to provide a good end termination to multi-stranded wires. Use of ferrules reduces the possibility of stray wire-strands short-circuiting adjacent terminals and their use is therefore highly recommended.

### 3. Power Supply

The T100MD2424+ PLC requires a single regulated, 12 to 24V (+/- 5% ripple) DC power supply for both the CPU and the I/Os (as shown in Figure 1). To use the T100MD2424+ at 12VDC you should place a jumper block on the two-pin header marked "J1-12V" near the power supply terminals. You must remember to remove the jumper when operating the PLC above 18V, otherwise the voltage regulator may overheat. (**Important:** see [Section 4](#) for the MCR power supply requirement.)

Please use only industrial grade linear or switching regulated power supply from established manufacturers. Using a poorly-made switching power supply can give rise to a lot of problems if the noisy high frequency switching signals are not filtered properly. **Note:** If your application demands very stable analog I/Os you should choose a linear power supply instead of a switching power source for the CPU.

Always place the power supply as near to the PLC as possible and use a separate pair of wire to connect the power to the PLC. Keep the power supply wires as short as possible and avoid running it along side high current cable in the same cable conduit. The T100MD-2424+ PLC will be reset when the power supply voltage dips below 9V. It is a good idea to connect a 470 $\mu$ F to 1000 $\mu$ F, 50V electrolytic capacitor near the power supply connector to suppress any undesirable voltage

glitches from conducting into the PLC. If other high current devices such as a frequency inverter were to affect the operation of the PLC, then you should also connect a diode before the capacitor to prevent reverse current which might flow back to the power supply, as shown in the following diagram:

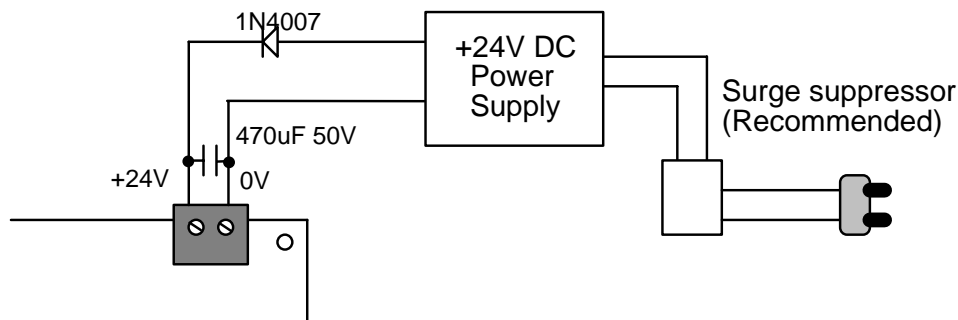

Figure 3

If the AC main is affected by nearby machines drawing large currents (such as large three-phase motors), you should use a surge-suppressor to prevent any unwanted noise voltage from being coupled onto the T100MD power supply. The required current rating for the power supply depends mainly on the total output current, taking into consideration the peak current demand and the duty cycle of the operation. Normally, a 2 to 4A, 24V DC switching power supply should be sufficient.

## 4. MCR Input and PWM Outputs

The T100MD2424+ features a special "Master Control Relay" (**MCR**) input right next to the power supply terminals. The MCR input is a hardware based control signal that is independent of the CPU and controls all but #5 & #6 of the output drivers in the PLC. The purpose of the MCR input is to allow the user to shut down most of the output drivers of the PLC under certain circumstances, but without cutting off the power to the PLC.

To enable the PLC output drivers, you must connect a +12 to +24VDC power to the MCR input. If the MCR input is turned off, all PLC outputs will be disabled regardless of the logic state of the outputs. However, the PLC input circuitry are unaffected and the CPU will continue to function.

Two digital outputs #7 & #8, which also double as PWM 1 & 2, are located next to the MCR input. These two outputs are different from the rest of the digital outputs in that they are of **PNP** design (i.e. active high, ON = +24V, OFF = 0V). These two PNP outputs get their source current from the MCR input, which means that they are also under the control of the MCR (See Section 7 for more details on these two outputs).

## 5. LCD Display Module

The built-in 14-pin **LCD DISPLAY MODULE PORT** (hence the suffix "MD") is compatible to the Hitachi HD44780 display controller which is a *de facto* industry standard. This allows low cost, easily available LCD modules to be connected directly to the PLC to implement very economical man-machine interface. You simply connect the LCD module to the T100MD's LCD port using a 14-way IDC ribbon

cable and header. Make sure that the pin number on the PLC matches that of the LCD module. Wrong cable connection can destroy the LCD port or the LCD module.

The +5V logic power required by the LCD module is supplied by the 14-pin header. However, **NEVER** connect the LCD backlight terminals to the +5V pin of the 14-pin header or the +5V output of the analog power supply, as this will overheat the PLC's voltage regulators. For modules with LED backlight, you can simply connect the backlight terminals in series with a 150Ω to 220Ω 5W resistor to the 24V power supply. The backlight wiring is illustrated in the Appendix section of this guide.

You may also use any of the industry standard 14-pin LCD modules. There are many different display sizes or character formats to choose from, e.g., 1x8, 1x16, 1x20, 2x16, 2x20, 1x40, 2x40 and 4x20. We strongly recommend those with Super-Twisted Nematics (STN) type which gives high contrast and wide viewing angle. The contrast of the LCD can be adjusted using the preset potentiometer R7 marked with the word "contrast" below the LCD connector.

### Programming the LCD Display

The **SETLCD** *y, x, string* TBASIC command allows you to easily display any string of up to 20 characters on the *y*<sup>th</sup> line starting from the *x*<sup>th</sup> column. E.g., to display the message "T100MD-2424+" on the 3<sup>rd</sup> line starting from the 5th character position from the left end of the screen, you use the command:

```
SETLCD 3, 5, "T100MD-2424+"
```

Normally, *y* = 1,2,3, 4; *x* = 1, 2, ... 20. Integers must be converted to strings using the STR\$( ) or HEX\$( ) before they can be displayed using SETLCD. You can use the concatenation operator "+" to combine a few components together in the command. E.g.

```
SETLCD 1,1,"Rm Temp = "+ STR$(ADC(1)/100,3)+CHR$(223)+"C"
```

The function STR\$(ADC(1)/100,3) reads the content of ADC channel #1, divides it by 100 and converts the result into a 3-digit string, the CHR\$(223) appends a special character which corresponds to the '°' symbol. E.g. if ADC(1) returns the value 1234, the final string being displayed will be : Rm Temp = 012 °C.

### Special Commands For LCD Display

Action	Command
1. Clear screen	SETLCD 0,1, CHR\$(1)
2. No cursor	SETLCD 0,1, CHR\$(12)
3. Underline Cursor	SETLCD 0,1, CHR\$(14)
4. Blinking Cursor	SETLCD 0,1, CHR\$(13)
5. Underline + Blinking Cursor	SETLCD 0,1, CHR\$(15)

If you use the SETLCD command with line #0, then the strings will be treated as special "instructions" to be sent to the LCD module to program it for various modes of operation. This includes blinking cursor, underline cursor or no cursor as well as display shift mode. You have to refer to the LCD manufacturer's data sheet for the detailed commands. Some of the most useful commands are listed below:

## 6. Digital Input Circuits

All inputs have green color LED indicators. Every 8 inputs are grouped together into a single strip of detachable screw terminal. All inputs are NPN types, meaning that to turn ON input, you should connect it to low-voltage rail (0V terminal) of the power supply as shown in the following diagram. The input numbers are marked on their screw terminals as well as on the PCB alongside the strip pin.

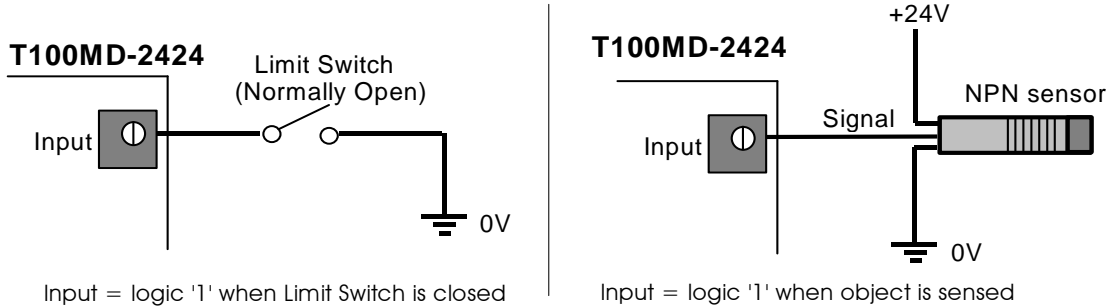

Input Voltage for Logic 0: Open Circuit or +10V to +24VDC  
 Input Voltage for Logic 1: 0V to +2.5V DC

## 7. Digital Output Circuits

### Outputs Electrical Specifications:

	Output #7 & #8	Output #1 to #24
<b>Output Driver type</b>	P-Channel power MOSFET with low $r_{DS} = 0.1 \Omega$	NPN Darlington Power Transistors & MOSFET
<b>Maximum Output Current:</b>	10A	1.0A
<b>Continuous Output Current</b>	2A	350mA
<b>Output Voltage when OFF</b>	Open circuit.	Resistor pull-up to 24V power rail
<b>Output Voltage when ON:</b>	+24V @10A	1.2V @1A
<b>Inductive Back EMF Bypass</b>	Yes	Yes

All outputs have red color LED indicators. T100MD2424+ PLC employs “sink” (NPN) type power transistors on all but two of its outputs that turn ON by sinking current from the loads to the 0V terminal. Figure 3 shows the wiring diagram of the digital outputs.

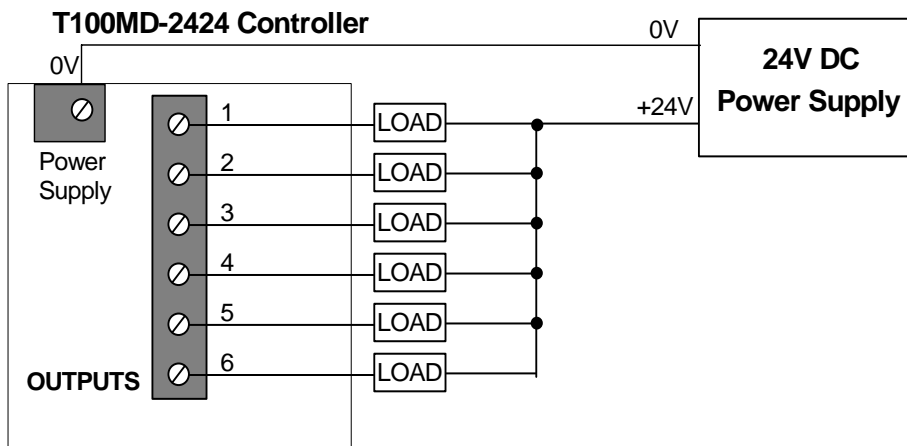

Figure 4 - Transistor Output Interfacing to Load

Output #7 & #8 are **PNP** type MOSFET outputs, meaning that they supply +24V voltage to the load when turned ON. These two outputs can each source up to **10A peak** or 2A continuous current @24VDC! They can also be configured as PWM outputs to drive heating elements or proportional valve using the SETPWM command. Figure 5 shows the wiring diagram for these two outputs.

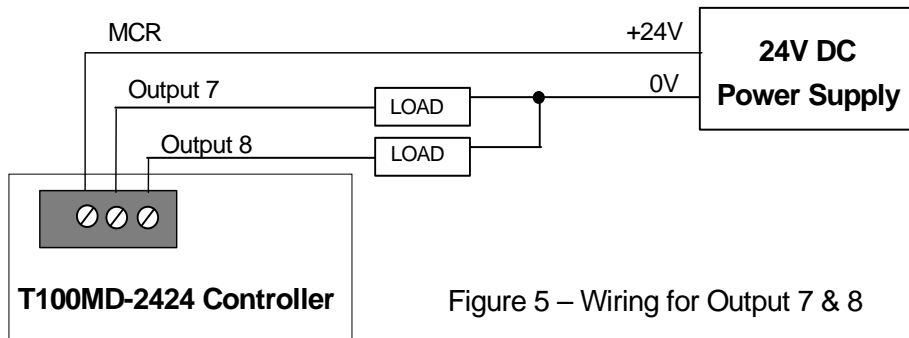

Figure 5 – Wiring for Output 7 &amp; 8

## 8. Analog I/Os

### 8.1 Analog Power Supply

The analog section of the PLC shares the same 12 to 24VDC power supply as the CPU. It will generate a stable 5V ( $\pm 1\%$  accuracy) regulated DC voltage which will be used internally as voltage reference and is available externally for use by other analog devices. The reference voltage output and the ground is available on a 2-way screw terminal block, and may be used as the source voltage for connecting to potentiometers. It is current-limited to 10mA by a 10 Ohm resistor RA3. If you need more current, you can replace RA3 with a lower resistance value.

The analog reference voltage can be calibrated by adjusting the preset potentiometer on the circuit board marked "**Avcc Adj**" until the reference voltage of 5.00V is reached.

### 8.2 Analog Input #1 to #8

Each T100MD-2424+ is equipped with 8 channels of built-in 10-bit A/D converters with a range of 0 - 5V full-scale. It is very easy to interface to other analog voltage or current input range by using external resistors as voltage dividers or current-to-voltage converters as shown in the following diagram:

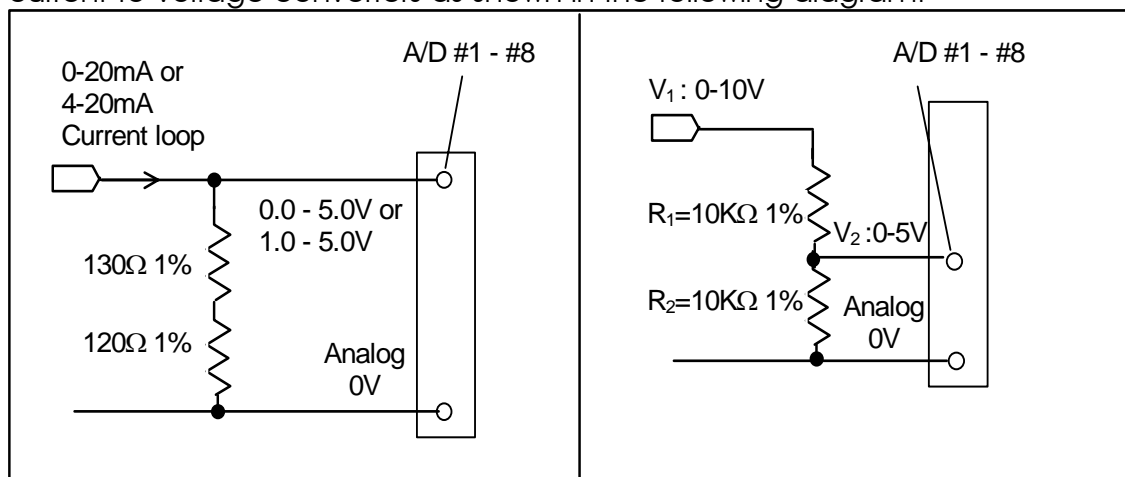

Converting 20mA current-loop to 0-5V

Converting 0-10V signal to 0-5V

Note that If the sensor has its own power supply, then you must connect the sensor "ground" to analog "AV<sub>ss</sub>" terminal to provide a common ground. All the analog inputs to the T100MD CPU are internally current-limited to guard against transient over-voltage damage. However, care should be taken to prevent applying excessive over-voltage to the analog inputs for a prolonged period of time which can lead to permanent damage of the ADC input.

### Using Potentiometer to Set Parameters

A potentiometer can provide a very low cost means for users to input parameters to the PLC such as setting of temperatures, timers or counter values, etc. The following diagram shows how easy it is to implement such a device using the 5V voltage reference output and an analog input:

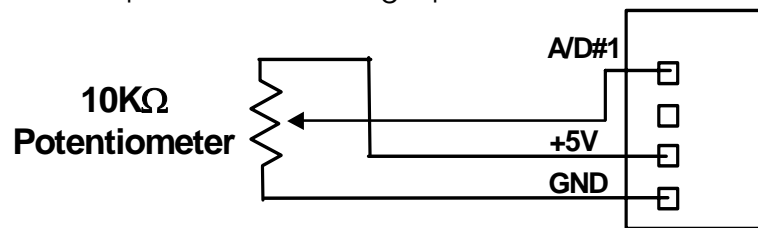

Very accurate parameters can be set if the LCD display is used as visual feedback of the settings.

### Reading Analog Input Data

The 8 analog input signals are read by the TBASIC command ADC(1) to ADC(8). For 10-bit resolution, the theoretical possible range is 0-1023. However, as explained in the programming manual, ADC(n) commands convert the result to a 12-bit number. This is done by multiplying the value by 4. Hence the data returned by ADC(n) command will be 0,4,8,... 4092.

### 8.3 Analog Outputs

T100MD2424+ features 2 channels of 8-bit Digital-to-Analog converter. D/A #1 shares the same pin as A/D #7 and D/A #2 shares the same pin as A/D #8. These two pins by default are A/D inputs after power-on RESET. You may configure either one or both of them as D/A outputs by executing the "setDAC" command on the respective channel(s).

Both D/A #1 and #2 are 0 to 5V signal level, high impedance unbuffered outputs. You need to connect them to external buffer amplifiers if you want to use them to deliver load current to drive external loads.

### Programming Analog Output

You can use the TBASIC command SETDAC 1,x to set the analog output to a 12-bit value x. (x = 0 to 4096). The actual analog outputs can only assume the value 0,16,32,48...4080 because of its 8-bit resolution, which is normalized to 12-bit by multiplying by 16. So if you execute SETDAC 1,20 the actual output will only be assigned a value = 16.

## Appendix 1: LCD Display For T100MD-2424+: Wiring Instruction

**Tri** currently supplies two models of back-lit LCD display modules for use with the T100MD-2424+ PLC. Each model is supplied with a 0.5m long 14-pin ribbon cable for connection to the T100MD-2424+'s LCD port.

To use the LCD, simply plug the 14-pin plug onto the LCD port header, making sure that pin #1 (the colored wire) of the ribbon cable aligns with pin #1 of the port header. (Pin 1 is the pin with a square solder pad and the pin number is also printed on the PCB.)

Wiring of the backlight differs slightly for the two models as shown below. It is assumed that the unit will be connected to the 24V power supply of the T100MD2424+ PLC. If you are using other voltages, then compute the values of the current limiting resistors to obtain the same backlight current.

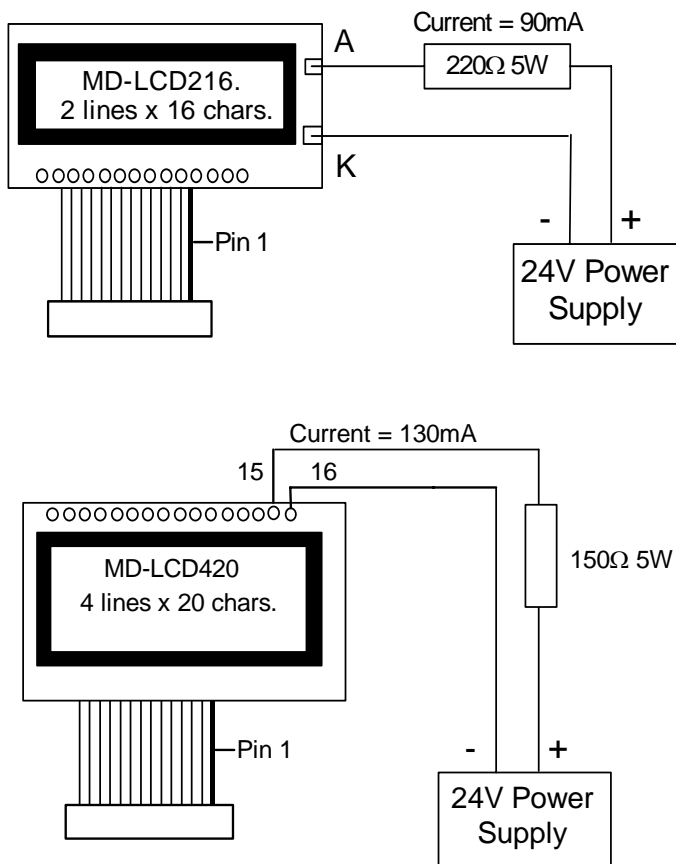

### IMPORTANT!

Please ensure that the current limiting resistor is in place and functioning properly before turning on the power supply. Connecting the LED backlight to the 24V power supply without the current limiting resistor will definitely destroy the backlight unit. Also, please ensure that the polarity is connected correctly, because reverse connection is likely to damage the backlight unit as well.

For MD-LCD420, the backlight is brought to a screw terminal via a small PCB. Use a multi-meter to check which terminal is connected to pin 15 (Anode) and 16 (Cathode-) if you are unsure of the polarity.

## Appendix 2 : EEPROM Write Protection Jumper

The T100MD2424+ PLC features an EEPROM write protection jumper J2. For normal programming, the jumper block for J2 should be placed at the "Enable" position. If J2 is placed at the "WP" position, the PLC's EEPROM is write-protected. In this case, the SAVE\_EEP statement will not work and if you transfer a new program to the PLC, the new program will reside temporarily in RAM and will not be saved in the EEPROM. It will also be lost when the PLC powers down.